

# PRODUCT INFORMATION PACKET

Model No: 182TTDR7601

Catalog No: M316

Other Purpose Motor, 5 HP, 3 Ph, 60 Hz, 208-230/460 V, 3600 RPM, 182JMV Frame, DP

Regal and are trademarks of Regal Rexnord Corporation or one of its affiliated companies.  
©2022 Regal Rexnord Corporation, All Rights Reserved. MC017097E



**Nameplate Specifications**

Output HP	<b>5 Hp</b>	Output KW	<b>3.7 kW</b>
Frequency	<b>60 Hz</b>	Voltage	<b>208-230/460 V</b>
Current	<b>14.2-13.2/6.6 A</b>	Speed	<b>3500 rpm</b>
Service Factor	<b>1.15</b>	Phase	<b>3</b>
Efficiency	<b>82.5 %</b>	Power Factor	<b>87</b>
Duty	<b>Continuous</b>	Insulation Class	<b>F</b>
Design Code	<b>B</b>	KVA Code	<b>J</b>
Frame	<b>182JMV</b>	Enclosure	<b>Drip Proof</b>
Thermal Protection	<b>No Protection</b>	Ambient Temperature	<b>40 °C</b>
Drive End Bearing Size	<b>6207</b>	Opp Drive End Bearing Size	<b>6205</b>
UL	<b>Recognized</b>	CSA	<b>Y</b>
CE	<b>Y</b>	IP Code	<b>55</b>
Number of Speeds	<b>1</b>		

**Technical Specifications**

Electrical Type	<b>Squirrel Cage Induction Run</b>	Starting Method	<b>Across The Line</b>
Poles	<b>2</b>	Rotation	<b>Reversible</b>
Resistance Main	<b>.88 Ohms</b>	Mounting	<b>Round</b>
Motor Orientation	<b>Shaft Down</b>	Drive End Bearing	<b>Ball</b>
Opp Drive End Bearing	<b>Ball</b>	Frame Material	<b>Rolled Steel</b>
Shaft Type	<b>JM</b>	Overall Length	<b>19.24 in</b>
Frame Length	<b>9.50 in</b>	Shaft Diameter	<b>0.875 in</b>
Shaft Extension	<b>4.28 in</b>	Assembly/Box Mounting	<b>F1 Only</b>
Outline Drawing	<b>035486-950</b>	Connection Drawing	<b>00501001ME</b>

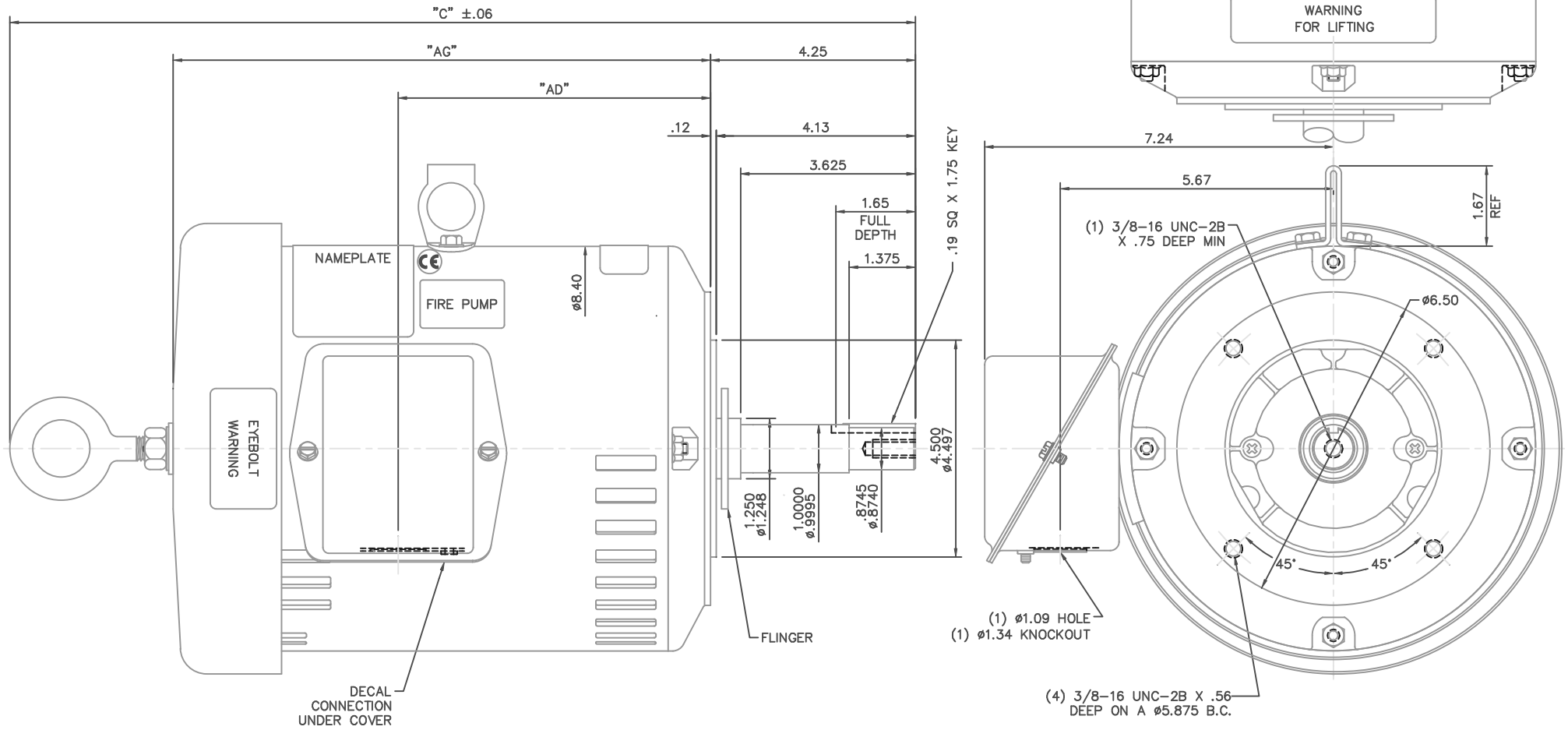

MAXIMUM FACE RUNOUT TO BE .004 T.I.R.  
 MAXIMUM PILOT ECCENTRICITY TO BE .004 T.I.R.  
 PERMISSIBLE SHAFT RUNOUT TO BE .004 T.I.R.

GASKETS THROUGHOUT

DASH NO.	"C"	"AG"	"AD"
850	18.24	10.65	5.98
900	18.74	11.15	6.48
950	19.24	11.65	6.98
1000	19.74	12.15	7.48
1050	20.24	12.65	7.98
1100	20.74	13.15	8.48
1150	21.24	13.65	8.98

NO.	REVISION	BY & DATE
01	ADDED EYEBOLT WARNING DECAL ECR 68275	RDW 10/31/05

TOLERANCES UNLESS SPECIFIED	
DEC.	INCHES
.X	±.1
.XX	±.03
.XXX	±.005
.XXXX	±.0005
CHK	ANG ±1/2'
RFP	4/26/04
DIST	

**MARATHON ELECTRIC**

TITLE: OUTLINE-- 180JM FRAME  
 DRIP PROOF-- "C" FACE-- JM PUMP

MAT'L: \_\_\_\_\_  
 FINISH: \_\_\_\_\_

CAD FILE: 035486

DRAWN	RDW 4/26/04
CHK	
APPD	SW 4/26/04
SCALE	1=2
REF	035456
FMF	139020
PREV	
SIZE	DRAWING NO.
B	035486
REV.	01

THIS DRAWING IN DESIGN AND DETAIL IS OUR PROPERTY AND MUST NOT BE USED EXCEPT IN CONNECTION WITH OUR WORK. ALL RIGHTS OF DESIGN AND INVENTION ARE RESERVED. THIS IS AN ELECTRONICALLY GENERATED DOCUMENT - DO NOT SCALE THIS PRINT

VIEW FROM OUTSIDE OF MOTOR AT SWITCH END.



VOLTAGE	L1	L2	L3	JOIN & INSULATE
HIGH	T1	T2	T3	(T4,T7) (T5,T8) (T6,T9)
LOW	T1,T7	T2,T8	T3,T9	T4,T5,T6

		TOLERANCES UNLESS SPECIFIED		DRAWN RDW 04/12/02					
		DEC.	INCHES	CHK					
		.X	±.1	APPD					
		.XX	±.01	SCALE 1=1					
		.XXX	±.005	REF FIG.2-51					
		.XXXX	±.0005	FMF					
NO.	REVISION	BY & DATE	CHK	ANG	±1/2'	FINISH	SIZE	DRAWING NO.	REV.
			RFP	04/12/02		CAD FILE	A	005010-01ME	



TITLE EXTERNAL WIRING DIAGRAM  
3 PHASE W/O PROTECTOR  
MAT'L. DECAL - 004014

THIS DRAWING IN DESIGN AND DETAIL IS OUR PROPERTY AND MUST NOT BE USED EXCEPT IN CONNECTION WITH OUR WORK ALL RIGHTS OF DESIGN AND INVENTION ARE RESERVED THIS IS AN ELECTRONICALLY GENERATED DOCUMENT - DO NOT SCALE THIS PRINT